

Hand membrane pump 1 ½"

Product information

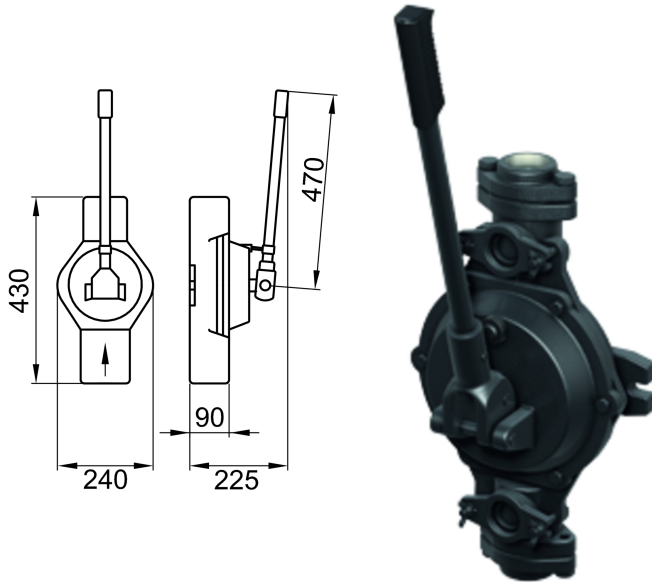

Used with

- Wastewater lifting plant

Description

- For fixing to wall
- Incl. hose
 - Clear width: 48 x 80 mm
- Incl. hose clamp
 - Clear width: 50 x 70 mm
 - Width: 12 mm
 - 2 pcs required