

Inlet valve DN 150

Product information

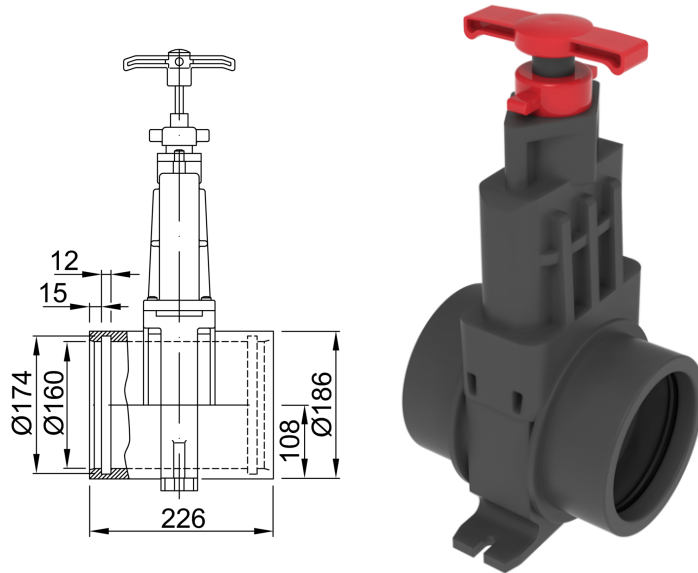

Used with

- Wastewater lifting plant
- Polyethylene grease separator
- Polyethylene starch separator
- Upstream tank plant
- Type 7 – Type 10

Description

- Made of PVC
- 160 mm push socket on both sides with rim sealing ring
- Overall dimensions: 226 x 510 mm (L x H)